

3177
3277
3177-CE
3277-CE

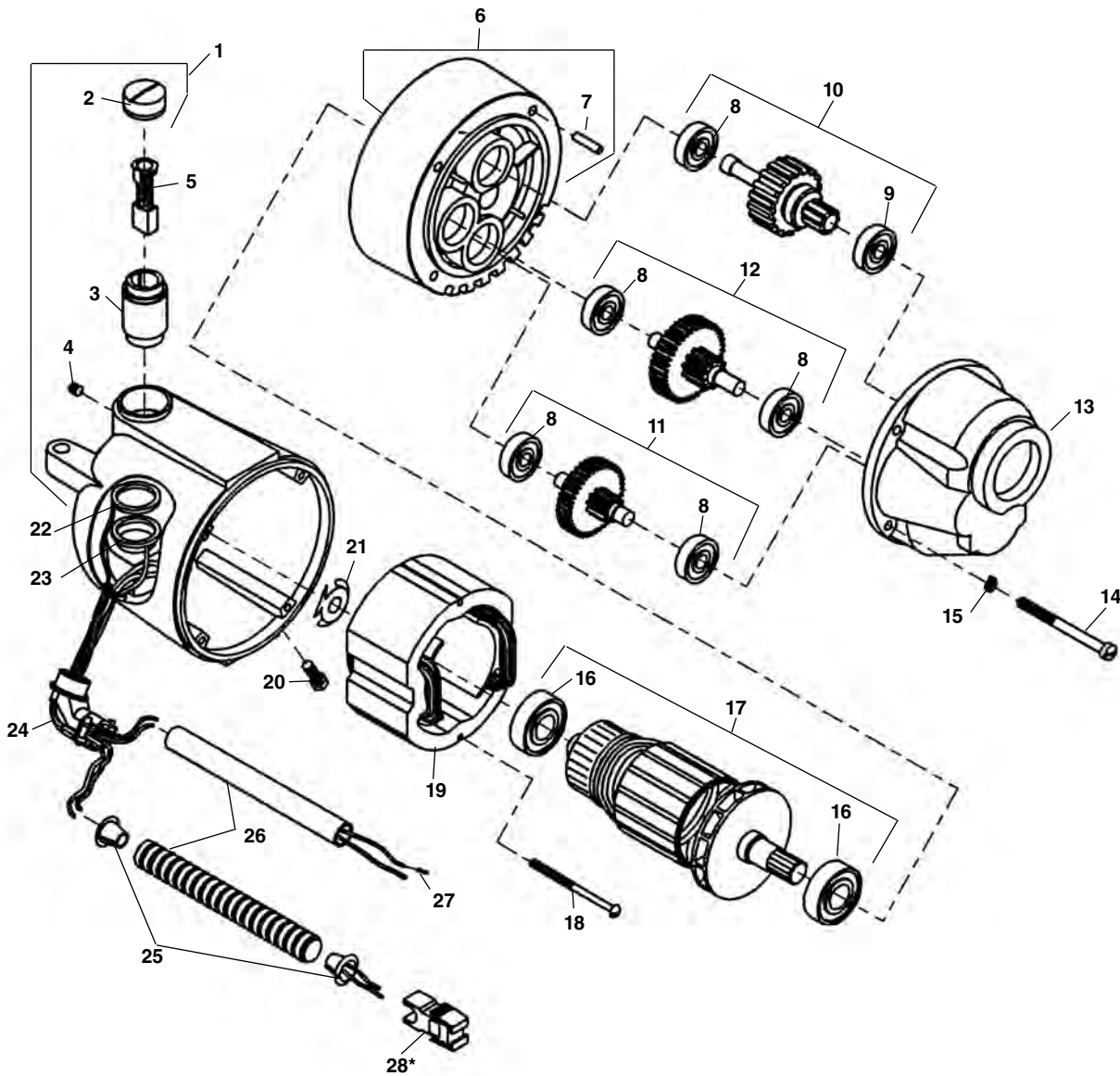

**NOTE: Order parts by Catalog Number only.
 DO NOT order by Reference Number.**

Ref. No.	Catalog No.	Description	Ref. No.	Catalog No.	Description	Ref. No.	Catalog No.	Description
†	87740	3177 Motor 115V	10	45370	Drive Gear	20	83500	Locking Screw
†	87780	3277 Motor 230V	11	44985	1st Gear Assembly	21	44580	Loading Spring
†	61202	3177-CE Motor 115V	12	45005	2nd Gear Assembly	22	86680	White Upper Lead
†	61207	3277-CE Motor 230V	13	42875	Gear Housing	23	86685	Red Lower lead
1	43160	Housing Assembly	14	45075	Screw (4)	24	46900	Connector 90 Degree
2	44545	Brush Cap Set	15	45150	Lock Washer	25	46890	E-918 Insulator (2)
3	45025	Brush Holder Set	16	44565	Armature Bearing (2)	26	47407	Flexible Conduit
4	39770	Set Screw (2)	17	44010	Armature (115V)		46880	Plastic Tube (CE Only)
5	44540	Brush Assembly Set		44030	Armature (230V)	27	88402	Wire Terminal (4) (CE Only)
6	43165	Fan Housing Assembly	18	44555	Mounting Screw (2)	28*	50552	Plug (Included in Switch Box Assy. 91187)
7	45165	Dowel Pin	19	44015	Field (115V)			
8	45060	Gear Bearings (5)		44035	Field (230V)			
9	45315	Front Bearing						

† Refer to Speed Change Chart for Optional Speeds on Page 25

**3181
3281
3181-CE
3281-CE**

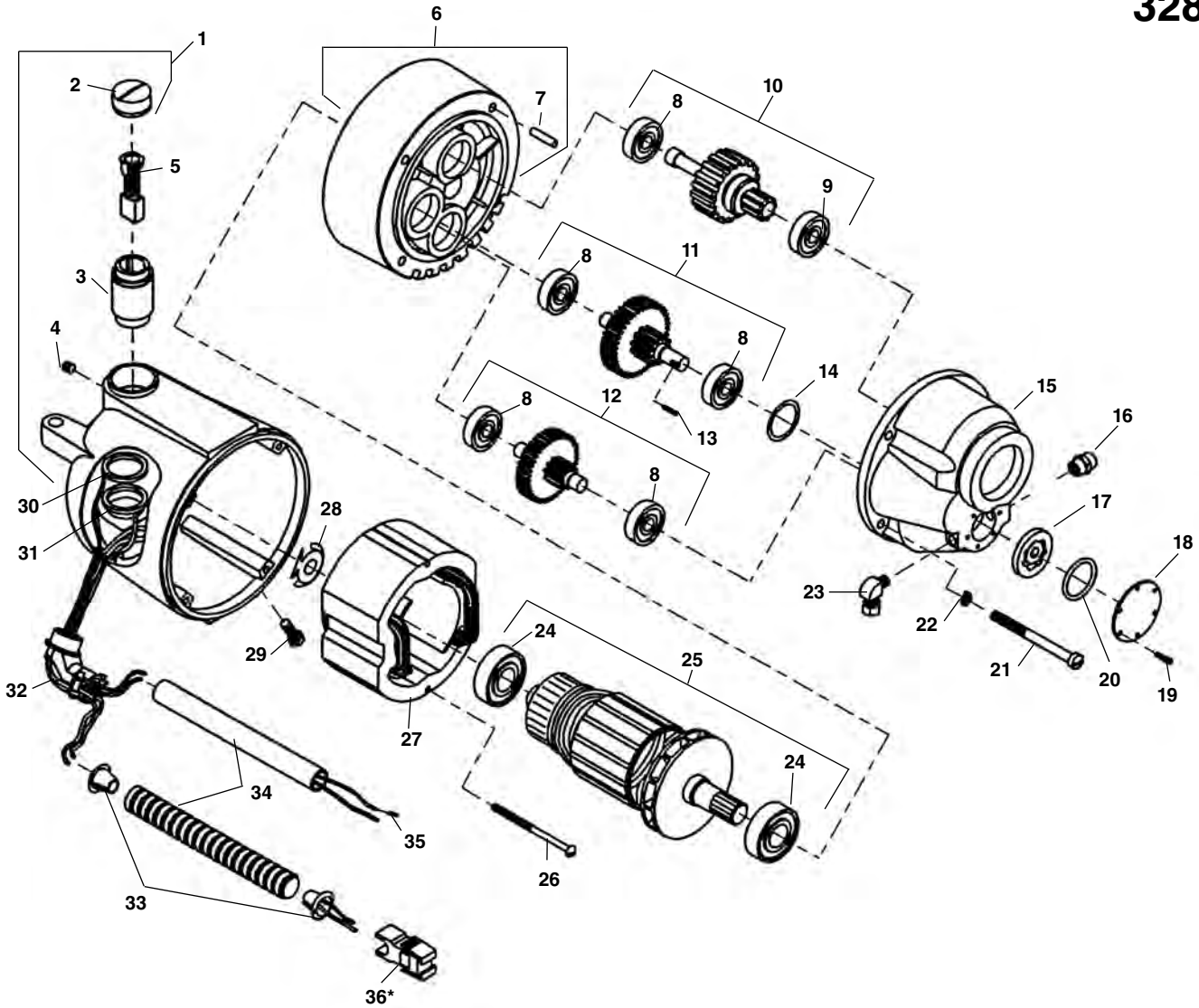

**NOTE: Order parts by Catalog Number only.
DO NOT order by Reference Number.**

Ref. No.	Catalog No.	Description	Ref. No.	Catalog No.	Description	Ref. No.	Catalog No.	Description
†	96810	3181 Motor 115V	12	45005	2nd Gear Assembly	26	44555	Mounting Screw (2)
†	96975	3281 Motor 230V	13	96885	Pin	27	44015	Field (115V)
†	61197	3181-CE Motor 115V	14	96880	Oil Seal		44035	Field (230V)
†	61192	3281-CE Motor 230V	15	96830	Gear Housing	28	44580	Loading Spring
1	43160	Housing Assembly	16	46830	Male Connector	29	83500	Locking Screw (2)
2	44545	Brush Cap Set	17	96870	Gerotor Set	30	86680	White Upper Lead
3	45025	Brush Holder Set	18	96840	Cover Plate	31	86685	Red Lower lead
4	39770	Set Screw (2)	19	96890	Screw (6)	32	46900	Connector 90
5	44540	Brush Assembly Set	20	96875	O Ring	33	46890	E-918 Insulator (2)
6	43165	Fan Housing Assembly	21	45075	Screw (4)	34	47407	Flexible Conduit
7	45165	Dowel Pin	22	45150	Lock Washer		46880	Plastic Tube (CE Only)
8	45060	Gear Bearings (5)	23	96910	Male Elbow	35	88402	Wire Terminal (4) (CE Only)
9	45315	Front Bearing	24	44565	Armature Bearing (2)	36*	50552	Plug (Included in Switch Box Assy. 91187)
10	45370	Drive Gear	25	44010	Armature (115V)			
11	97000	1st Gear Assembly		44030	Armature (230V)			

† Refer to Speed Change Chart for Optional Speeds on Page 25

2192
2292
2192R
2292R

Motor

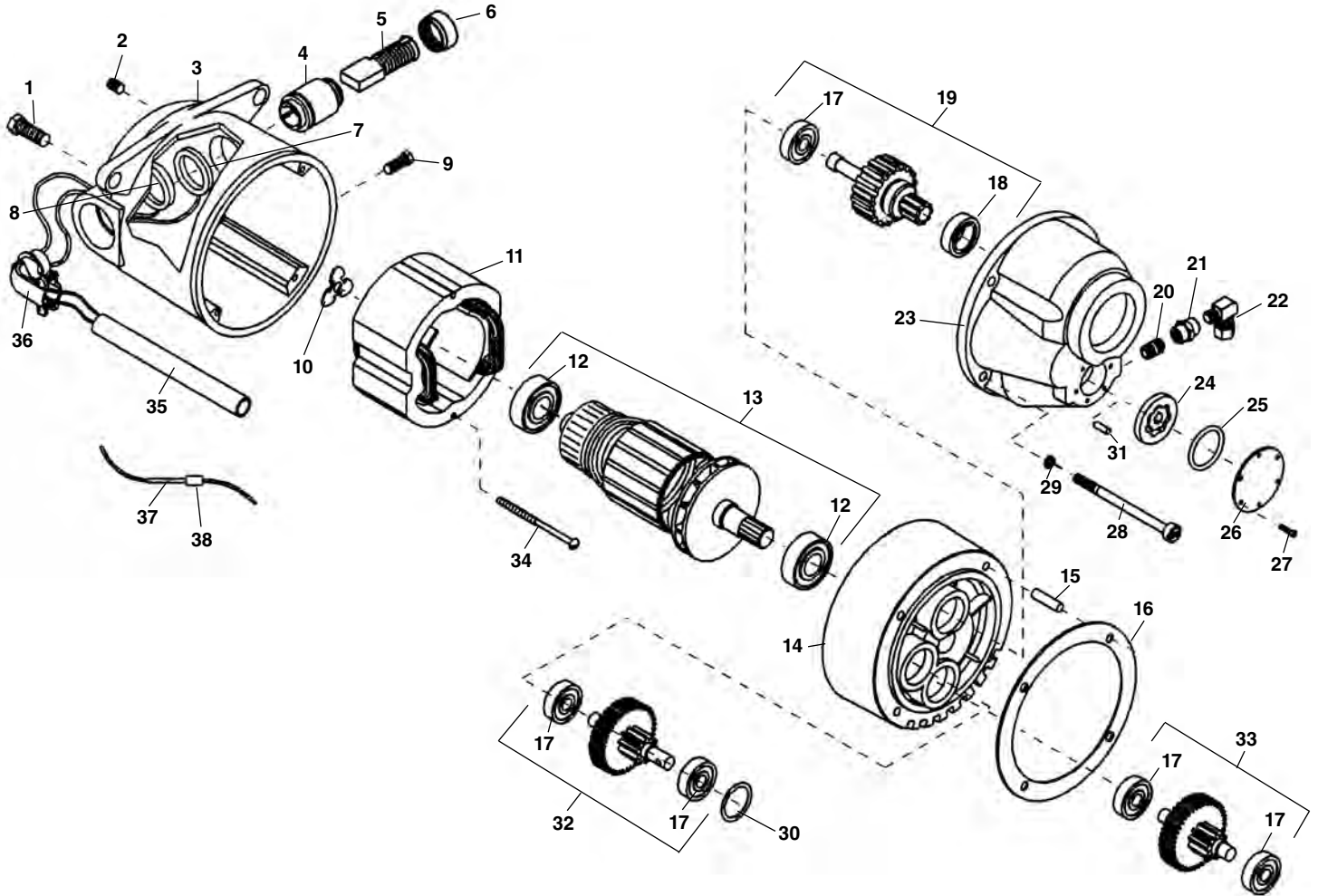

**NOTE: Order parts by Catalog Number only.
 DO NOT order by Reference Number.**

Ref. No.	Catalog No.	Description	Ref. No.	Catalog No.	Description	Ref. No.	Catalog No.	Description
—	72127	Motor Model 2292, 230V	12	44565	Armature Bearing (2)	26	96840	Cover Plate
—	54797	Motor Model 2192R, 115V	13	52497	115V Armature	27	96890	Screw #4 x 3/8" (6)
—	54802	Motor Model 2292R, 230V		54542	230V Armature	28	45075	Screw 1/4" - 20
1	85915	Motor Mounting Bolt (2)	14	54552	Fan Housing Assembly	29	45150	Lock Washer 1/4"
2	39770	Set Screw 1/4" - 20 x 1/4" (2)	15	45165	Dowel Pin	30	96880	Oil Seal
3	52482	Motor Housing	16	52502	Gasket	31	96885	Pin
4	45025	Brush Holder Set (2)	17	44760	Gear Bearing	32	52522	1st Gear Assembly
5	44540	Brush Assembly Set (2)	18	45315	Front Bearing	33	54547	2nd Gear Assembly
6	44545	Brush Cap Set (2)	19	54537	Main Drive Gear Assembly	34	44555	Screw 10 - 24 x 3"
7	86685	Red Brush Lead	20	52507	1/8" NPT Close Nipple (2)	35	63382	Plastic Tube
8	86680	White Brush Lead	21	52512	1/8" Coupling (2)	36	46900	90 Connector
9	83500	Field Locking Screw	22	52517	Elbow Compression Fitting (2)	—	47412	Male Wire Connector
10	44580	Loading Spring	23	96830	Gear Case	—	52537	Female Wire Connector
11	44015	Field 100/115V	24	96870	Gerotor Set	37	16946	Male Connector
	44035	Field 230V	25	96875	"O" Ring	38	16956	Female Connector

1157
1177
2357
2377

Motors

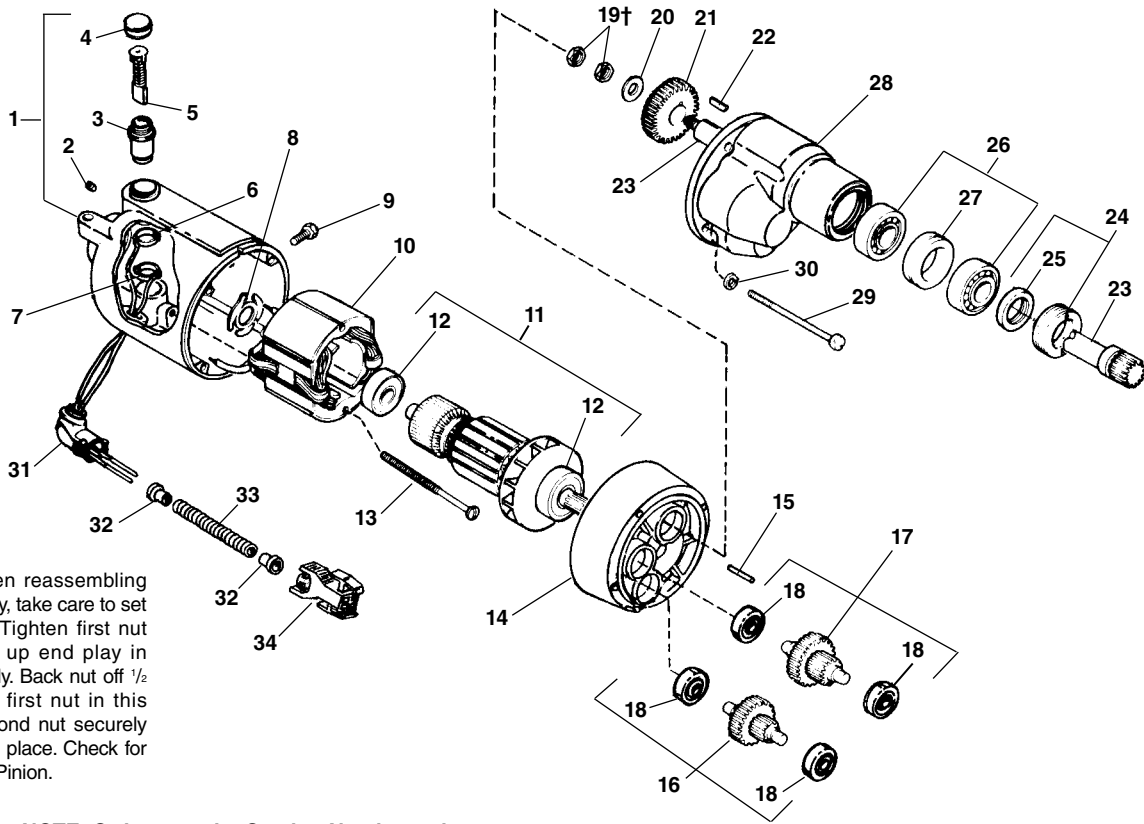

†Service Note: When reassembling Drive Pinion Assembly, take care to set Jam Nuts properly. Tighten first nut moderately to take up end play in Pinion Shaft Assembly. Back nut off 1/2 turn. While holding first nut in this position, tighten second nut securely against first to lock in place. Check for free rotation of Drive Pinion.

NOTE: Order parts by Catalog Number only. DO NOT order by Reference Number.

Ref. No.	Catalog No.	Description	Ref. No.	Catalog No.	Description
1	43160	Housing	18	45060	Gear Bearing (4)
2	39770	Set Screw 1/4" - 20 x 1/4" (2)	19†	40350	Lock Nut 3/8" - 24 (2)
3	45025	Brush Holder Set	20	45035	Washer
4	44545	Brush Cap Set	21	See Chart	Main Drive Gear
5	44540	Brush Set	22	45015	Key 3/32" Sq.
6	87865	White Upper Lead	23	44960	Drive Pinion
7	87870	Red Lower Lead	24	45010	Lock Nut w/Seal
8	44580	Loading Spring	25	45085	Seal
9	83500	Screw 1/4" - 20 x 3/4"	26	45040	Bearing Set w/Spacer
10	44015	Field - 115V	27	45045	Spacer
	44035	Field - 230V	28	43170	Housing
11	44010	Armature - 115V	29	45075	Screw 1/4" - 20 x 3"
	44030	Armature - 230V	30	45150	Lock Washer (4)
12	44565	Armature Bearing (2)	31	46900	Connector 90°
13	44555	Mounting Screw (2)		46905	Connector 45°
14	43165	Fan Housing Assembly	32	46890	Insulator (2)
15	45165	Dowel Pin	33	47412	Flexible Conduit
16	See Chart	1st Gear Assembly	34	50552	Plug
17	See Chart	2nd Gear Assembly			

SPEED CHANGE GEAR CHART MACHINE MODEL NO. 400A - 535 - 802

Model No.	Volts	Spindle Speed	Ref. #11	Ref. No. 16 - 1st Intermediate Gear Assembly	Ref. No. 17 - 2nd Intermediate Gear Assembly	Ref. No. 21 Drive Gear
1177 2377	115V 230V	36 STD.	Armature Pinion - 14 T.	PART NO. 44985 (E-2600-X) 51 T. GEAR 12 T. PINION	PART NO. 45005 (E-2601-X) 42 T. GEAR 13 T. PINION	PART NO. 44965 (E-2597) 48 T.
1177A 2377A	115V 230V	54 STD. ON 802		PART NO. 44985 (E-2600-X) 51 T. GEAR 12 T. PINION	PART NO. 44990 (E-2601-AX) 42 T. GEAR 18 T. PINION	PART NO. 44865 (E-1926) 43 T.
1177B	115V	72		PART NO. 44975 (E-2600-BX) 51 T. GEAR 15 T. PINION	PART NO. 44995 (E-2601-BX) 39 T. GEAR 18 T. PINION	PART NO. 44865 (E-1926) 43 T.
1177C 2377C	115V 230V	102		PART NO. 44980 (E-2600-CX) 51 T. GEAR 19 T. PINION	PART NO. 45000 (E-2601-CX) 35 T. GEAR 18 T. PINION	PART NO. 44865 (E-1926) 43 T.

*Supplied with Motor Complete

Motor

**1194
1194A
2394**

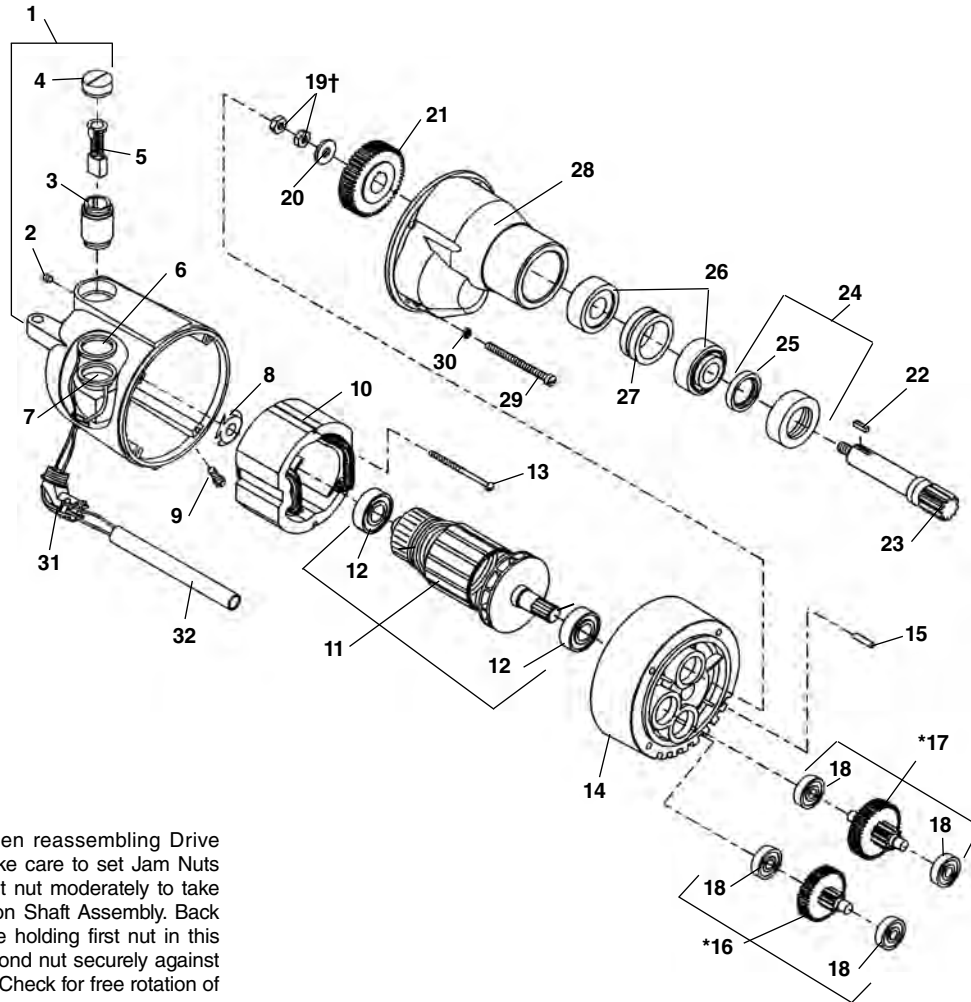

†Service Note: When reassembling Drive Pinion Assembly, take care to set Jam Nuts properly. Tighten first nut moderately to take up end play in Pinion Shaft Assembly. Back nut off 1/2 turn. While holding first nut in this position, tighten second nut securely against first to lock in place. Check for free rotation of Drive Pinion.

**NOTE: Order parts by Catalog Number only.
DO NOT order by Reference Number.**

Ref. No.	Catalog No.	Description	Ref. No.	Catalog No.	Description
—	64447	1194 Motor, 115V, 36RPM	16*	62022	1st. Int. Gear Assy.— 36RPM
—	64452	1194A Motor, 115V, 54RPM		44985	1st. Int. Gear Assy.— 54RPM
—	64457	2394 Motor, 230V, 36RPM	17*	52527	2nd. Int. Gear Assy.— 36RPM
1	43160	Field Housing		44990	2nd. Int. Gear Assy.— 54RPM
2	39770	Set Screw 1/4" x 20 x 1/4" (2)	18	45060	Bearing (4)
3	45025	Brush Holder Set	19†	40350	Lock Nut 3/8" — 54RPM
4	44545	Brush Cap Set	20	45035	Washer
5	44540	Brush Set	21	44965	Drive Gear — 36RPM
6	87865	White Upper Lead		44865	Drive Gear — 54RPM
7	87870	Red Lower Lead	22	45015	Key 5/32" Square
8	44580	Load Spring	23	44960	Drive Pinion
9	83500	Screw 1/4" x 20 x 3/4"	24	45010	Lock Nut w/Seal
10	44015	Field 115V	25	45085	Seal
	44035	Field 230V	26	45040	Bearing Set w/Spacer
11*	52497	Armature — 115V - 36RPM	27	45045	Spacer
*	52492	Armature — 230V	28	43170	Gear Housing
	44010	Armature — 115V - 54RPM	29	45075	Screw 1/4" - 20 x 3" (4)
12	44565	Armature Bearing (2)	30	45150	Lock Washer (4)
13	44555	Mounting Screw (2)	31	46900	Right Angle Connector
14	54552	Fan Housing Assembly	32	64462	PVC Tubing
15	45165	Dowel Pin			

Note: *Helical gear not interchangeable with old style 535 machines.

**1102-CE
1103-CE
2302-CE
2303-CE**

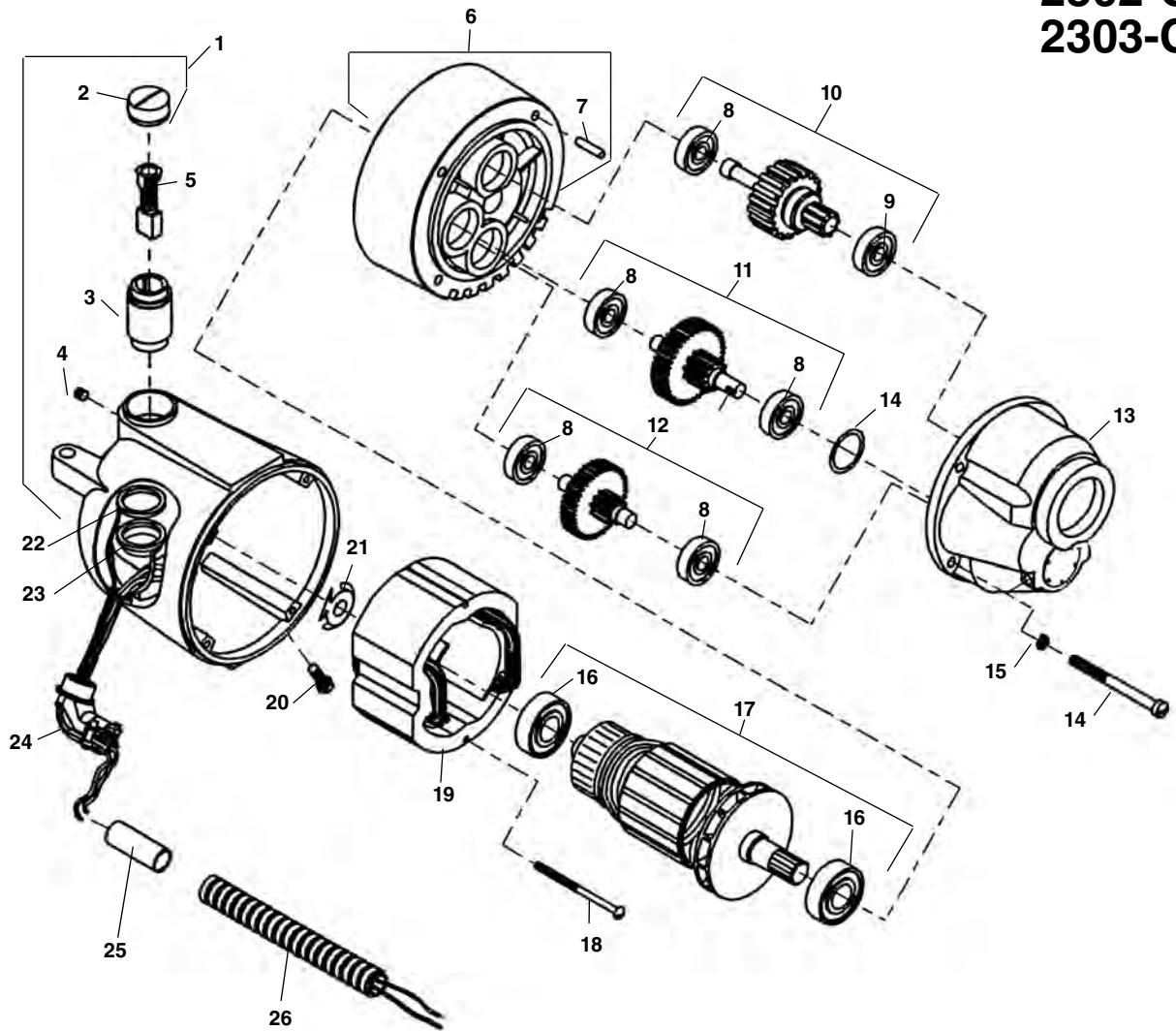

**NOTE: Order parts by Catalog Number only.
DO NOT order by Reference Number.**

Ref. No.	Catalog No.	Description	Ref. No.	Catalog No.	Description	Ref. No.	Catalog No.	Description
1	43160	Housing Assembly	11	44985	1st Gear Assembly 1103-CE and 2303-CE	17	44010	Armature 1103-CE (115V)
2	44545	Brush Cap Set		62022	1st Gear Assembly 1102-CE and 2302-CE		44030	Armature 2303-CE (230V)
3	45025	Brush Holder Set					52497	Armature 1102-CE (115V)
4	39770	Set Screw (2)	12	45005	2nd Gear Assembly 1103-CE and 2303-CE		52492	Armature 2302-CE (230V)
5	44540	Brush Assembly Set		52527	2nd Gear Assembly 1102-CE and 23032	18	44555	Mounting Screw (2)
6	43165	Fan Housing Assembly 1103-CE and 2303-CE				19	44015	Field (115V)
	54552	Fan Housing Assembly 1102-CE and 2302-CE	13	42875	Gear Housing		44035	Field (230V)
7	45165	Dowel Pin	14	45075	Screw (4)	20	83500	Locking Screw (2)
8	45060	Gear Bearings (5)	15	45150	Lock Washer	21	44580	Loading Spring
9	45315	Front Bearing	16	44565	Armature Bearing (2)	22	86680	White Upper Lead
10	45370	Drive Gear				23	86685	Red Lower lead
						24	46900	Connector 90 Degree
						25	63377	Ferrite Bead
						26	95690	Flexible Conduit

1101 2301

Motor

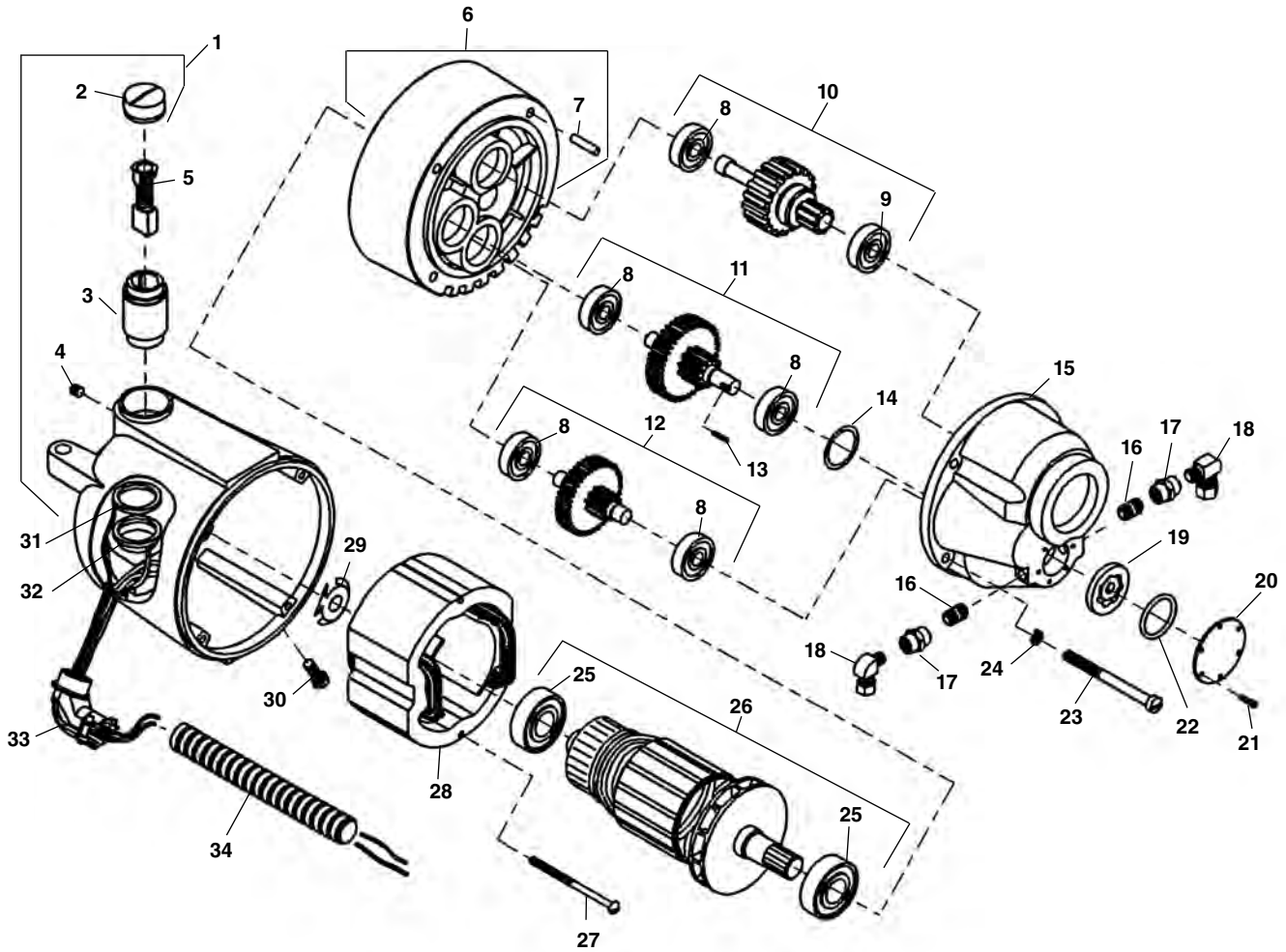

**NOTE: Order parts by Catalog Number only.
DO NOT order by Reference Number.**

Ref. No.	Catalog No.	Description	Ref. No.	Catalog No.	Description	Ref. No.	Catalog No.	Description
—	96442	1101 Motor 115V	11	52522	1st Gear Assembly	24	45150	Lock Washer
—	21208	2301 Motor 230V	12	52527	2nd Gear Assembly	25	44565	Armature Bearing (2)
—	25353	1101A Motor 115V 54 RPM	13	96885	Pin	26	52497	Armature (115V)
1	43160	Housing Assembly	14	96880	Oil Seal	26	52492	Armature (230V)
2	44545	Brush Cap Set	15	96830	Gear Housing	27	44555	Mounting Screw (2)
3	45025	Brush Holder Set	16	52507	Pipe Nipple 1/8" NPT (2)	28	44015	Field (115V)
4	39770	Set Screw (2)	17	52512	Coupling 1/8" NPT (2)	44035	Field (230V)	
5	44540	Brush Assembly Set	18	52517	90° Elbow Fitting (2)	29	44580	Loading Spring
6	54552	Fan Housing Assembly	19	96870	Gerotor Set	30	83500	Locking Screw (2)
7	45165	Dowel Pin	20	96840	Cover Plate	31	96942	White Upper Lead
8	45060	Gear Bearings (5)	21	46130	Screw (6)	32	96492	Red Lower lead
9	45315	Front Bearing	22	96875	O Ring	33	46900	Connector 90
10	96437	Drive Gear	23	45075	Screw (4)	34	96482	Flexible Conduit

Motor

**3092
3192
3292
3192R
3292R**

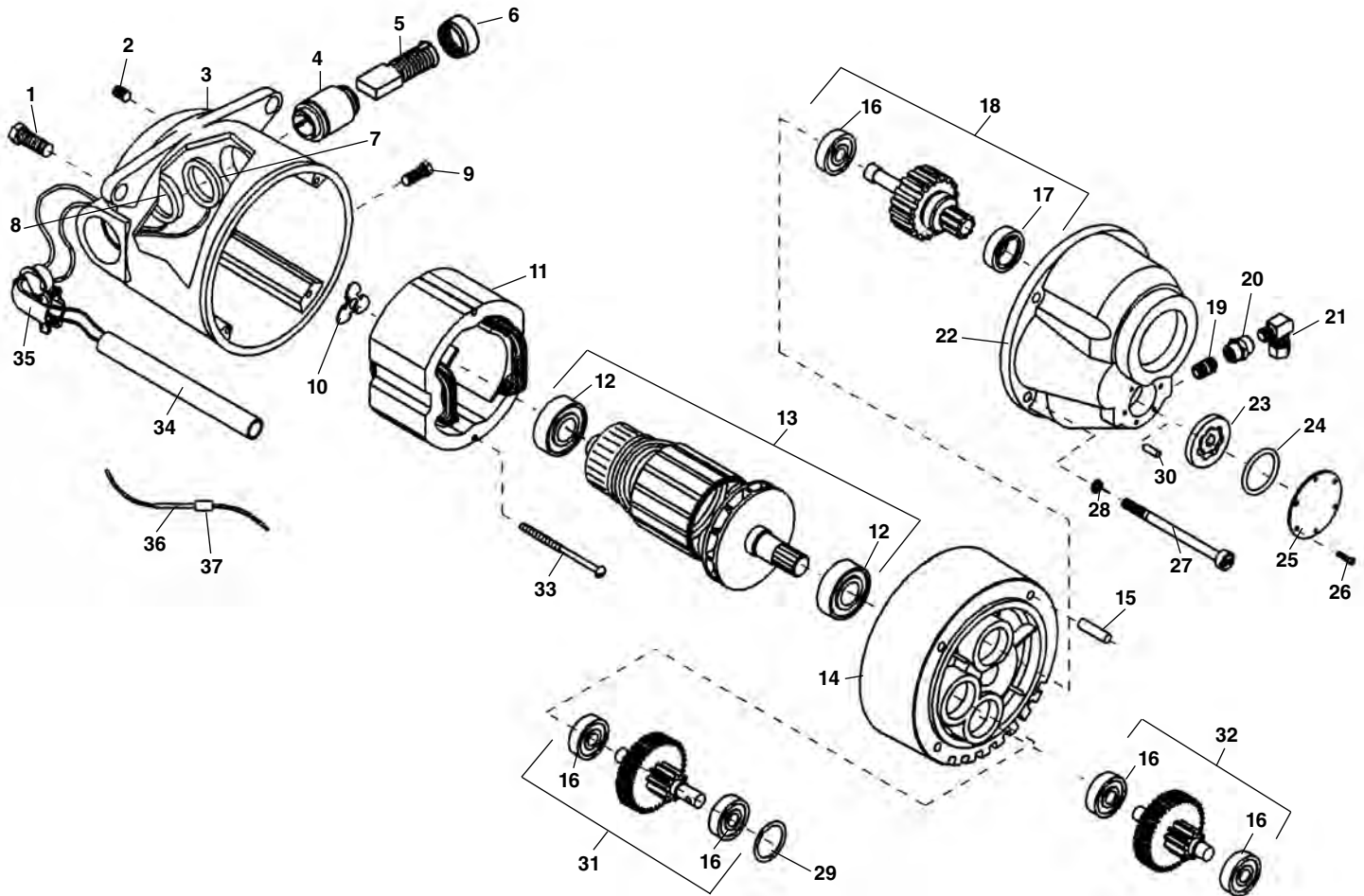

**NOTE: Order parts by Catalog Number only.
DO NOT order by Reference Number.**

Ref. No.	Catalog No.	Description	Ref. No.	Catalog No.	Description	Ref. No.	Catalog No.	Description
—	52457	Motor Model 3092, 100V	11	44015	Field 100/115V	23	96870	Gerotor Set
—	52462	Motor Model 3192, 115V	—	44035	Field 230V	24	96875	O-Ring
—	52467	Motor Model 3292, 230V	12	44565	Armature Bearing (2)	25	96840	Cover Plate
—	52472	Motor Model 3192R, 115V Rev.	13	52487	100V Armature	26	96890	Screw #4 x 3/8" (6)
—	52477	Motor Model 3292R, 230V Rev.	—	52497	115V Armature	27	45075	Screw 1/4" - 20
1	85915	Motor Mounting Bolt (2)	—	52492	230V Armature	28	45150	Lockwasher 1/4"
2	39770	Set Screw 1/4" - 20 x 1/4" (2)	14	54552	Fan Housing Assembly	29	96880	Oil Seal
3	52482	Motor Housing	15	45165	Dowel Pin	30	96885	Pin
4	45025	Brush Holder Set (2)	16	44760	Gear Bearing	31	52522	1st Gear Assembly
5	44540	Brush Assembly Set (2)	17	45315	Front Bearing	32	52527	2nd Gear Assembly
6	44545	Brush Cap Set (2)	18	45370	Main Drive Gear Assembly	33	44555	Screw 10-24 x 3"
7	86685	Red Brush Lead	19	52507	1/8" NPT Close Nipple (2)	34	63382	Plastic Tube
8	86680	White Brush Lead	20	52512	1/8" Coupling (2)	35	46900	90 Connector
9	83500	Field Locking Screw	21	52517	Elbow Compression Fitting (2)	36	16946	Male Wire Connector
10	44580	Loading Spring	22	96830	Gear Case	37	16956	Female Wire Connector